

NOTE:

- Align the lock washer tabs with the spline washer grooves.
- Always install the thrust washer and snap ring with the chamfered (rolled) edge facing away from the thrust load.
- Install the snap ring so that its end gap aligns with the groove in the splines.
- Make sure that the snap ring is fully seated in the shaft groove after installing it.

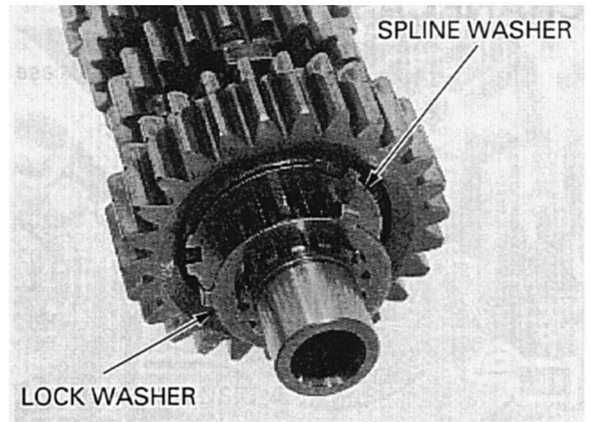

Install the countershaft assembly, aligning the hole in the needle bearing outer race with the dowel pin, and the set ring with the ring groove. Rest the pin on the ball bearing into the pin groove.

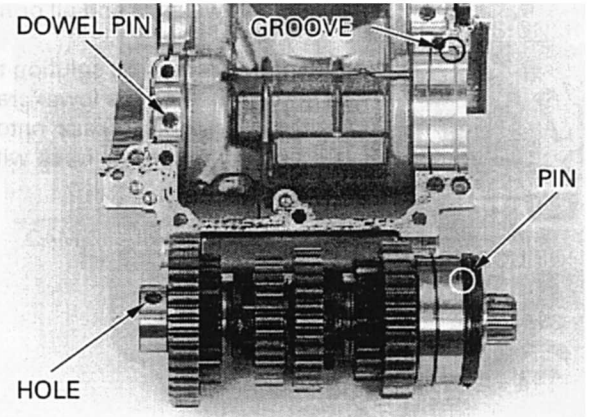

Install the mainshaft assembly, aligning the hole in the needle bearing outer race with the dowel pin.

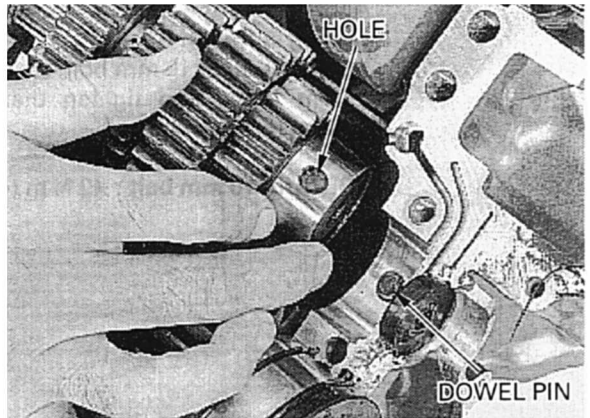

Apply locking agent to the set plate bolt threads. Install the mainshaft bearing set plate with the "OUT SIDE" mark facing out and tighten the bolts.

Assemble the crankcase halves (page 11-10).

