

Apply engine oil to each gear teeth and each bearing sliding area of the shafts.

Install the final gear shaft into the left crankcase. Install the countershaft into the counter gear while aligning the countershaft splines with the counter gear splines and install them to the left crankcase.

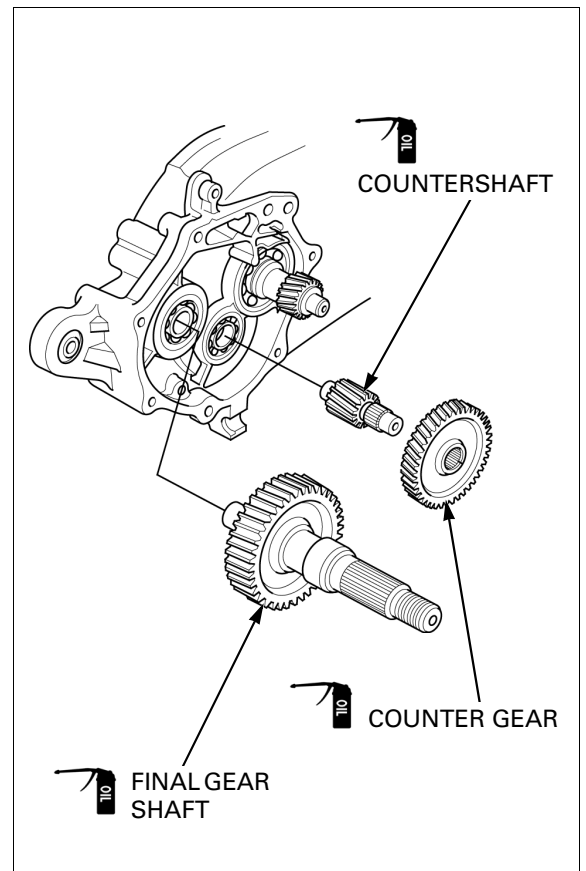

Apply sealant to the final reduction case mating surface.

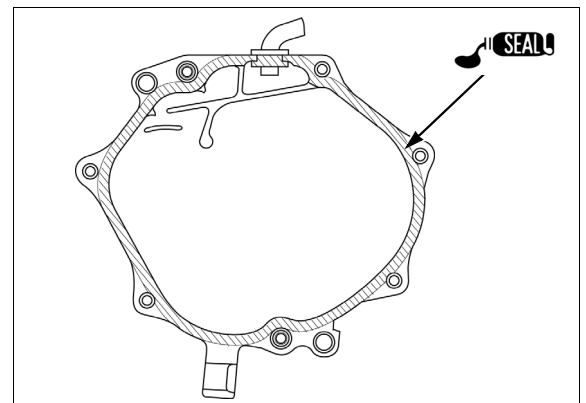

Install the dowel pins to the left crankcase.

