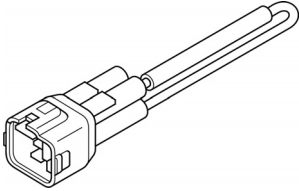
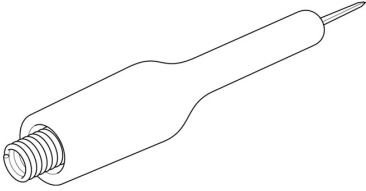
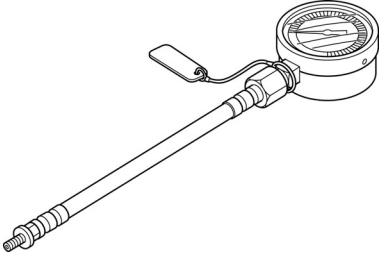
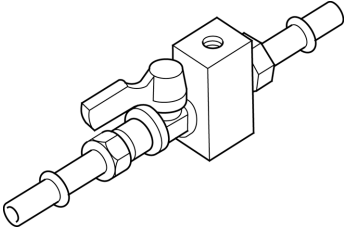
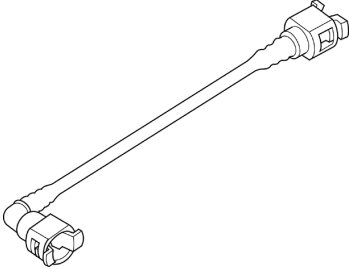
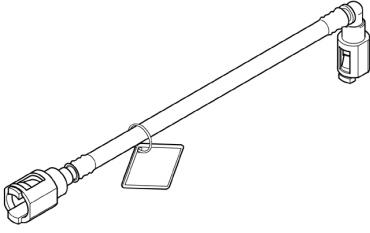

FUEL SYSTEM (Programmed Fuel Injection)

TORQUE VALUES

Fuel pump mounting nut	12 N·m (1.2 kgf·m, 9 lbf·ft)
Left floor panel side frame mounting bolt	49 N·m (5.0 kgf·m, 36 lbf·ft)
Sensor unit mounting torx screw	3.4 N·m (0.3 kgf·m, 2.5 lbf·ft)
Throttle cable bracket screw	3.4 N·m (0.3 kgf·m, 2.5 lbf·ft)
IACV mounting torx screw	2.1 N·m (0.2 kgf·m, 1.5 lbf·ft)
Bank angle sensor mounting screw	1.2 N·m (0.1 kgf·m, 0.9 lbf·ft)
PCV solenoid valve mounting bolt	6 N·m (0.6 kgf·m, 4.4 lbf·ft)
ECT sensor	25 N·m (2.5 kgf·m, 18 lbf·ft)
O ₂ sensor	25 N·m (2.5 kgf·m, 18 lbf·ft)

TOOLS

<p>DLC short connector 070PZ-ZY30100</p> 	<p>Test probe 07ZAJ-RDJA110</p> 	<p>Fuel pressure gauge 07406-0040004</p> 
<p>Pressure gauge manifold 07ZAJ-S5A0111</p> 	<p>Pressure gauge hose attachment 07ZAJ-S5A0120</p> 	<p>Pressure gauge hose attachment 07ZAJ-S5A0130</p> 
<p>Pressure gauge hose joint 07ZAJ-S5A0150</p> 