

FRONT WHEEL/SUSPENSION/STEERING

Install the right and left handlebars onto the fork sliders.
Install the top bridge while aligning its holes with the handlebar stopper pins.

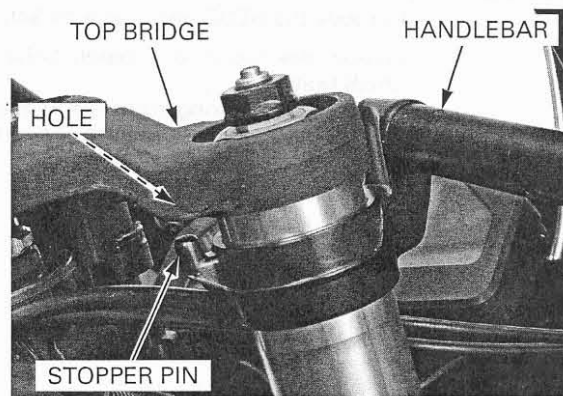

Install the steering stem nut and tighten it to the specified torque.

TORQUE: 103 N·m (10.5 kgf·m, 76 lbf·ft)

Tighten the top bridge pinch bolts to the specified torque.

TORQUE: 23 N·m (2.3 kgf·m, 17 lbf·ft)

Seat the handlebar upper surface with the top bridge lower surface, then tighten the handlebar pinch bolts to the specified torque.

TORQUE: 26 N·m (2.7 kgf·m, 20 lbf·ft)

Install the steering damper (page 14-34).

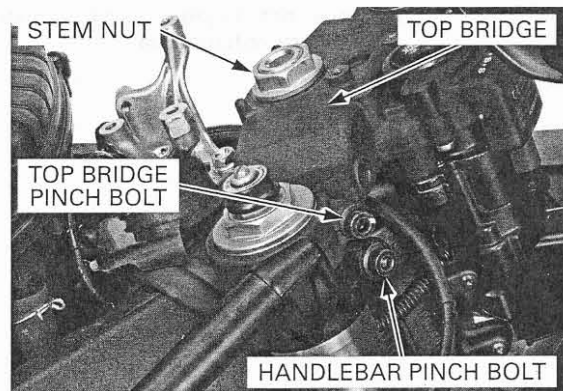

HANDLEBAR WEIGHT REPLACEMENT

Straighten the weight retainer tab by the screwdriver or punch.

Apply lubricant spray through the tab locking hole to the rubber for easy removal. Temporarily install the handlebar weight and screw, then remove the inner weight by turning the handlebar weight.

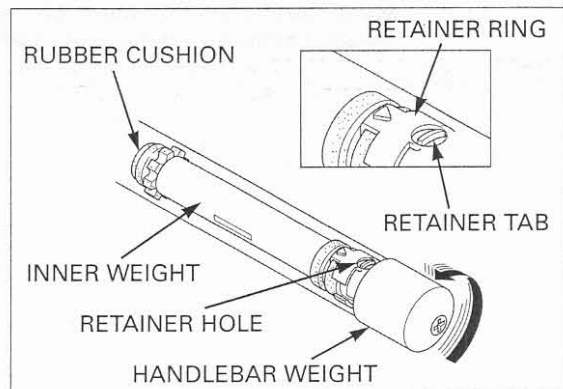

Remove the handlebar weight from the inner weight.
Discard the retainer ring.

Install the new retainer ring onto the inner weight.
Install the handlebar weight onto the inner weight while aligning the bosses and grooves each other.
Install and temporarily tighten the mounting screw.

