

Turn the crankshaft clockwise 1/2 turn (180°), align the index line on the ignition pulse generator rotor facing up as shown.

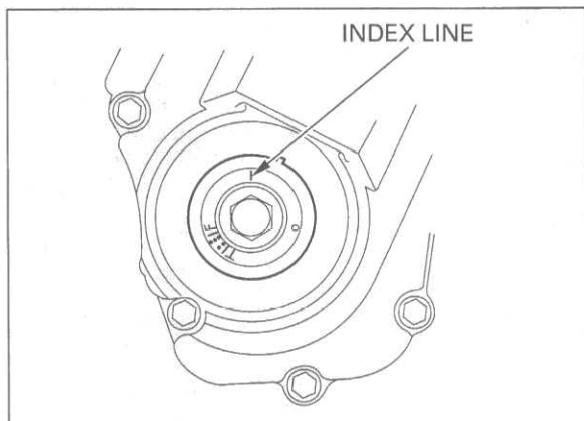

Check the valve clearance for the No.1 and No.3 cylinder exhaust valves using a feeler gauge.

### VALVE CLEARANCE:

EX:  $0.22 \pm 0.03$  mm ( $0.009 \pm 0.001$  in)

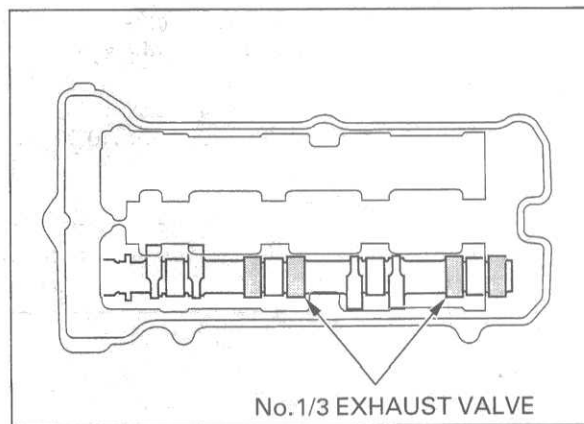

## ADJUSTMENT

Remove the camshaft (page 8-5).  
Remove the valve lifters and shims.

### NOTE:

- Shim may stick to the inside of the valve lifter. Do not allow the shims to fall into the crankcase.
- Mark all valve lifters and shims to ensure correct reassembly in their original locations.
- The valve lifter can be easily removed with a valve lapping tool or magnet.
- The shims can be easily removed with a tweezers or magnet.

Clean the valve shim contact area in the valve lifter with compressed air.

