

# FRONT WHEEL/SUSPENSION/STEERING

## Fork tube bushing

Visually inspect the slider and fork tube bushings. Replace the bushings if there is excessive scoring or scratching, or if the teflon is worn so that the copper surface appears on more than 3/4 of the entire surface.

Check the back-up ring; replace it if there is any distortion at the points shown.

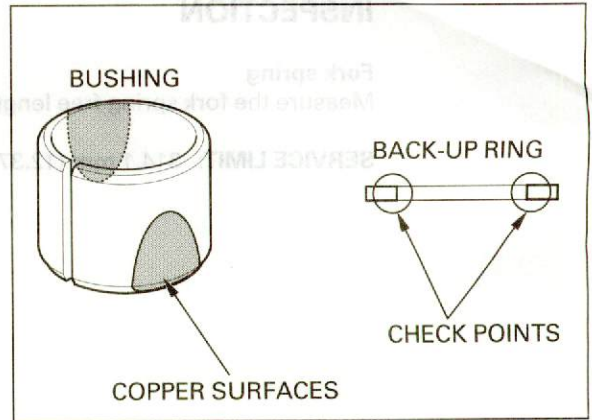

## BRAKE CALIPER PIVOT BEARINGS REPLACEMENT

Remove the dust seals and pivot collar.

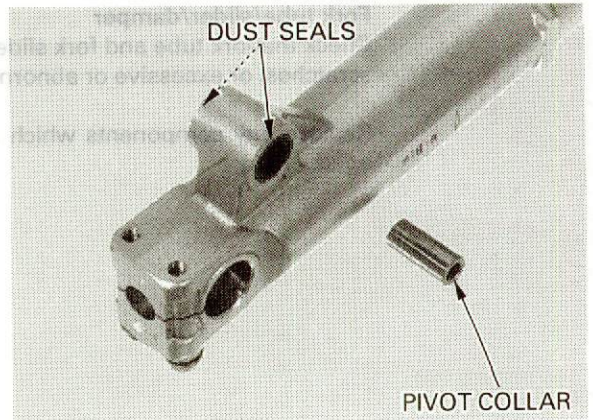

Press out the pivot bearings using the special tool.

### TOOL:

**Driver shaft** 07946-KA50000

Apply grease to the pivot bearings. Press the needle bearing into the fork slider using the same tool.

### NOTE:

Install the bearing so that the bearing cage below 3.5 mm (0.14 in) from the pivot surface.

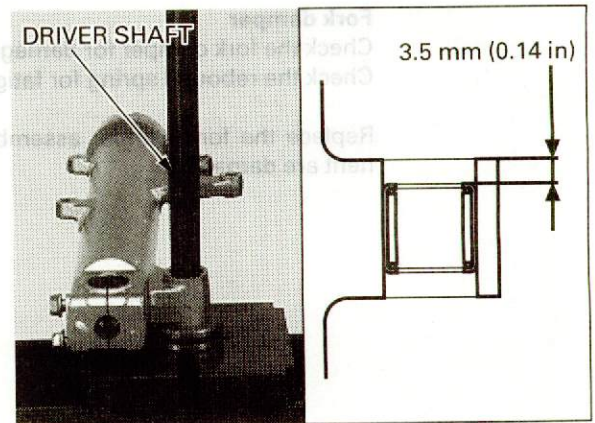

Apply grease to the new dust seal lips. Install the dust seals and pivot collar.

